

Extender™

Self-Contained Oscillating Tape System

ContactClean™ Web by PolymagTek, Inc.

Extender™

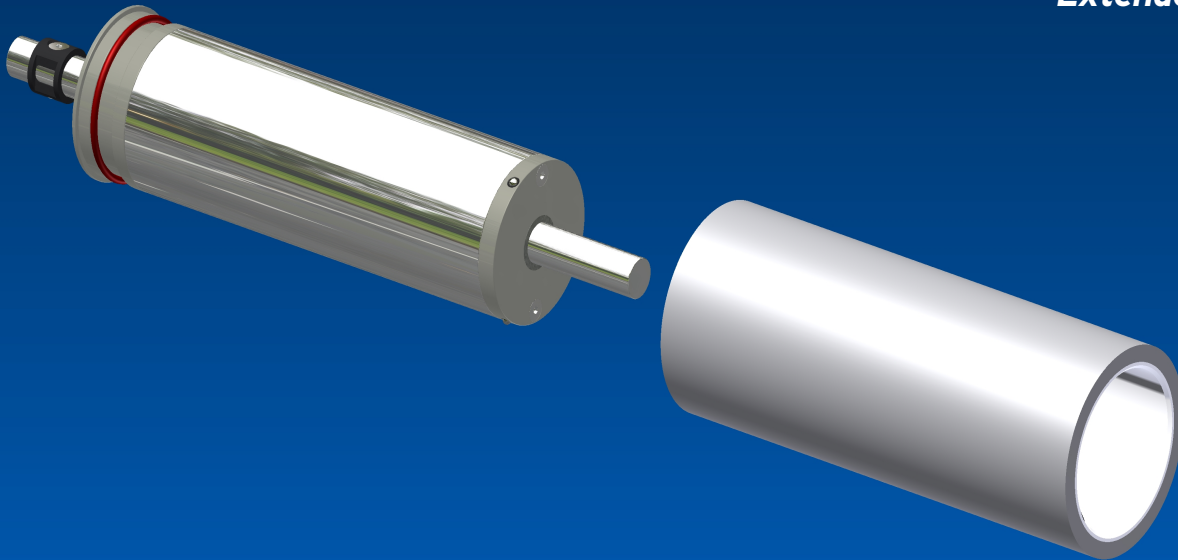

This self-contained, oscillating tape roll traverses 1.5" (38mm) across the face of the Contact Cleaning Roll (CCR) thereby eliminating the "line of travel" saturation caused by slit edge contamination. This "line of travel" saturation creates an increased amount of contamination build-up on specific areas of the tape leading to premature tape change out, while other areas of the tape are still highly functional. The tape oscillation feature helps to spread the contaminants out, thus extending the life of your adhesive tape by up to 1200% with regard to slit edge contamination. This product is only available through Polymag® Tek and only on Polymag® Tek Open Frame models.

Applications

- Easy to retrofit in Polymag® Tek Open-Frame models:
 - 2RNWC-SS
 - 2RNWC-CT
 - 2RNWC-CT-3II
 - 2RNWC-CT-3IIA
 - 2RNWC-IIA
 - 2RNWC-3II
 - 2RNWC-3IIA
 - 3RNWC-II
 - 3RNWC-3IIA
 - 4RNWC-II
 - 4RNWC-IIA
 - 4RNWCV-II
 - 4RNWCV-IIA

Features

- 1.5" overall side to side oscillation
- Available for 3" I.D. adhesive tape rolls
- Adaptable to all Polymag® Tek open-frame models
- Eliminates the "line of travel" slit-edge contamination
- Extends tape life by up to 1200% with regard to slit edge contamination
- Quick tape roll change system

Process Parameters

- 3" I.D. tape rolls
- Available on 8" face lengths and greater
- Web speeds on 3" I.D. by 30" face length tape rolls up to 800 fpm
- Please consult with Polymag® Tek on maximum web speeds for face lengths greater than 30"

Patent No.: 8,783,177



 **PolymagTek**
INCORPORATED

www.polymagtek.com

Phone: 1.800.787.0830 • Fax: 585.235.8395
215 Tremont Street, Rochester, NY 14608