

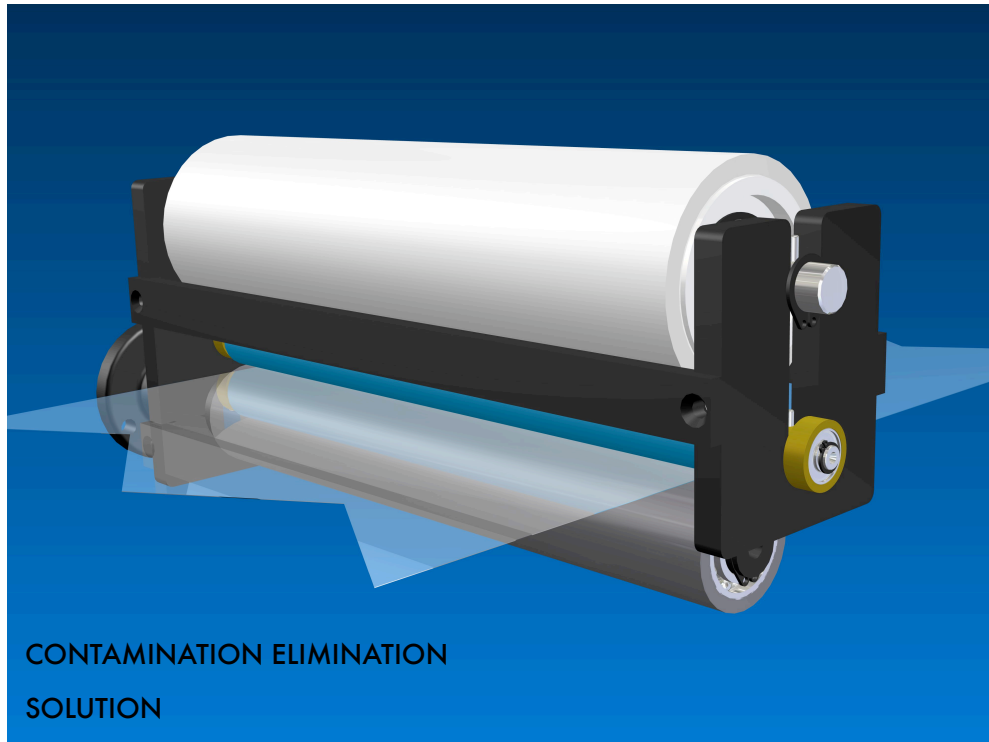

2RNWC-CT

APPLICATIONS:
NILPETER TYPE
PRESSES



FEATURES:

- 1 SIDED GRAVITY NIP- SIMPLE RUGGED DESIGN
- 1.25" O.D. CONTACT CLEANING ROLL
- CANTILEVERED DESIGN FOR PRESS WITH BACK PLATE ONLY!
- SHAFTED TAPE MOUNTING STYLE
- SIMPLE SUPPORTED CLAMPS ON EXISTING ROLLER
- PLATED STEEL CONSTRUCTION
- CAN BE SAFELY INSTALLED IN A SOLVENT ENVIRONMENT
- ALTERED DESIGNS AVAILABLE

PROCESS PARAMETERS:

- MAXIMUM SPEED 700 FPM
- MINIMUM WIDTH 2" MAXIMUM 30"
- NO TAPE CHANGE ON THE FLY

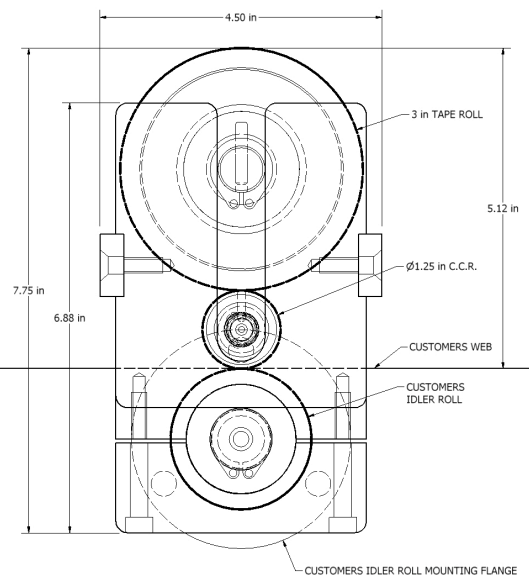

POLYMAG TEK INC.
WWW.POLYMAGTEK.COM

1/800-787-0830

FAX: 585-235-8395

215 TREMONT STREET, ROCHESTER, NY
14608