

4RNWC-IIB

APPLICATIONS:

2 SIDED
CLEANING

OSC



CONTAMINATION ELIMINATION
SOLUTION

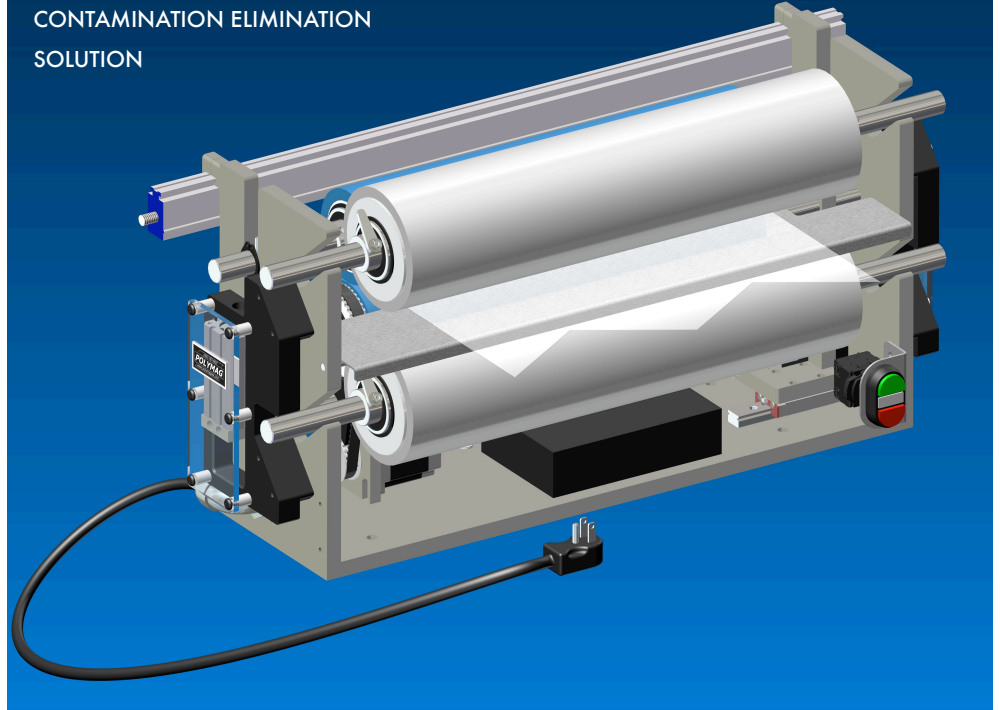

FEATURES:

- 2 SIDED GRAVITY NIP-SIMPLE RUGGED DESIGN
- 3.0" O.D. CONTACT CLEANING ROLLS
- 2" OSCILLATION FEATURE FOR SLIT-EDGE CONTAMINATION - EXTENDS TAPE USEFULNESS BY 16X
- PNEUMATIC CYLINDERS TO SEPARATE ROLLS WHEN MACHINE STOPS
- SHAFTED TAPE MOUNTING STYLE
- TOP TAPE CHANGE ACCESS
- STATIC ELIMINATION
- NICKEL PLATED STEEL CONSTRUCTION
- ALTERED DESIGNS AVAILABLE

PROCESS PARAMETERS:

- MAXIMUM SPEED 700 FPM
- MINIMUM WIDTH 2" MAXIMUM 40"
- NO TAPE CHANGE ON THE FLY
- CAN BE TILTED UP TO 45%

OPTIONS:

- INFEEED OR EXIT IDLE ROLLERS
- CCR TACH SENSOR TO AUTO ENGAGE/DISENGAGE WHEN MACHINE STARTS/STOPS
- ON/OFF SWITCH
- DRIVE MOTOR FOR USE AS SHEET CLEANER

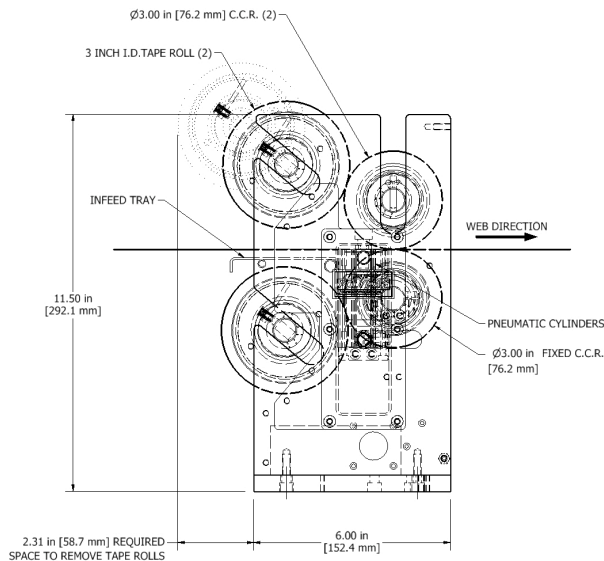

POLYMAG TEK
WWW.POLYMAGTEK.COM

1/800-787-0830 FAX: 585/235-8395
215 TREMONT ST
ROCHESTER, NY 14608

