

**POLYMAG**<sup>®</sup>

**4RNWCV-IIA**

APPLICATIONS:

2 SIDED  
CLEANING  
VERTICAL WEB

CONTAMINATION ELIMINATION  
SOLUTION

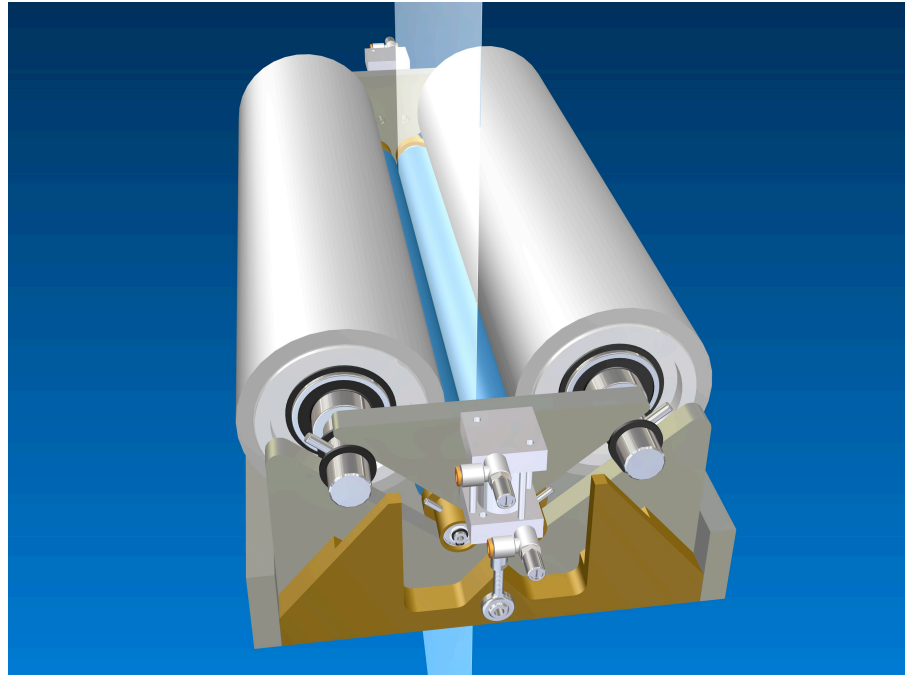

**OPTIONS:**

- STATIC BARS
- INFEEED IDLE ROLLS

**FEATURES:**

- 2 SIDED GRAVITY NIP-SIMPLE RUGGED DESIGN
- 1.25" O.D. CONTACT CLEANING ROLLS
- PNEUMATIC CYLINDERS TO SEPARATE ROLLS WHEN MACHINE STOPS
- SHAFTED TAPE MOUNTING STYLE
- TOP TAPE CHANGE ACCESS
- NICKEL PLATED STEEL CONSTRUCTION
- CAN BE DESIGNED FOR A SOLVENT ENVIRONMENT
- ALTERED DESIGNS AVAILABLE

**PROCESS PARAMETERS:**

- MAXIMUM SPEED 700 FPM
- MINIMUM WIDTH 2" MAXIMUM 40"
- NO TAPE CHANGE ON THE FLY
- VERTICAL WEB DIRECTION

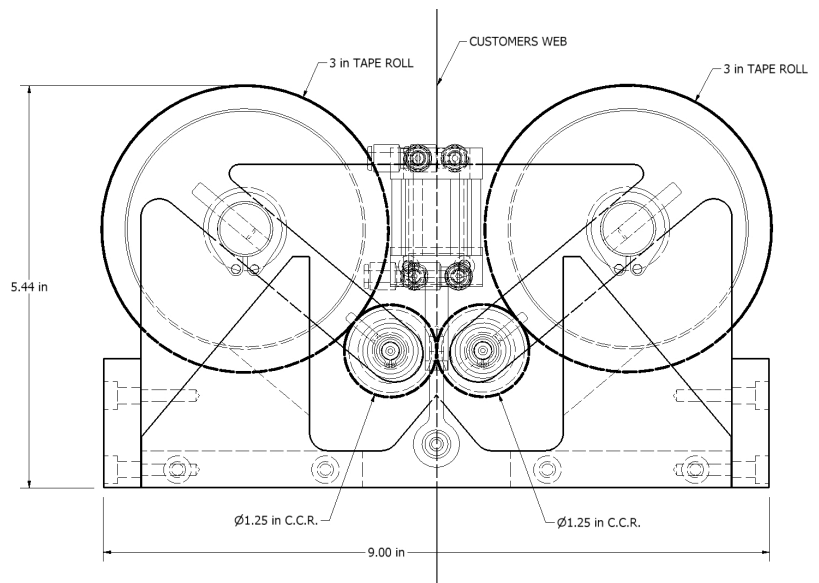

POLYMAG TEK INC.  
[WWW.POLYMAGTEK.COM](http://WWW.POLYMAGTEK.COM)  
1/800-787-0830  
FAX: 585/235-8395  
215 TREMONT ST.  
ROCHESTER, NY 14608