

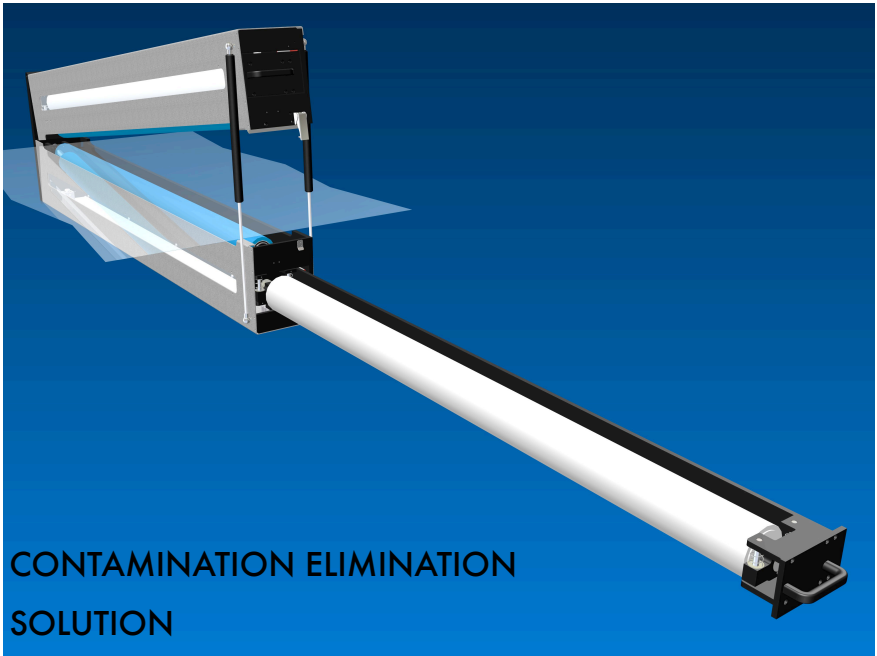

# 4RWWC-CD

APPLICATIONS:

2 SIDED  
CLEANING  
WEB OR SHEET



CONTAMINATION ELIMINATION  
SOLUTION

## FEATURES:

- 2 SIDED PNEUMATIC NIP-SIMPLE RUGGED DESIGN
- 3.0" O.D. CONTACT CLEANING ROLLS
- PNEUMATIC CYLINDERS TO SEPARATE ROLLS WHEN MACHINE STOPS
- SPRING GUDGEON TAPE /DRAWER SLIDE
- SIDE TAPE CHANGE ACCESS
- COATED ALUMINUM CONSTRUCTION
- CAN BE DESIGNED FOR A SOLVENT ENVIRONMENT
- ALTERED DESIGNS AVAILABLE

## PROCESS PARAMETERS:

- MAXIMUM SPEED 700 FPM
- MINIMUM WIDTH 30" MAXIMUM 60"
- NO TAPE CHANGE ON THE FLY
- HORIZONTAL WEB DIRECTION

## OPTIONS:

- STATIC BARS
- INFEEED IDLE ROLLS

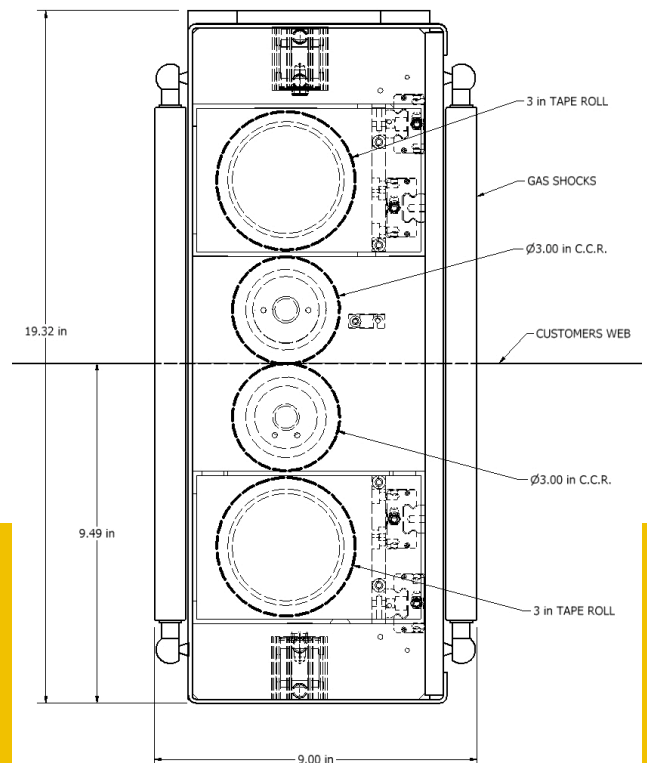

POLYMAG TEK  
[WWW.POLYMAGTEK.COM](http://WWW.POLYMAGTEK.COM)  
 1/800-787-0830  
 FAX: 585/235-8395  
 215 TREMONT ST  
 ROCHESTER, NY 14608

