

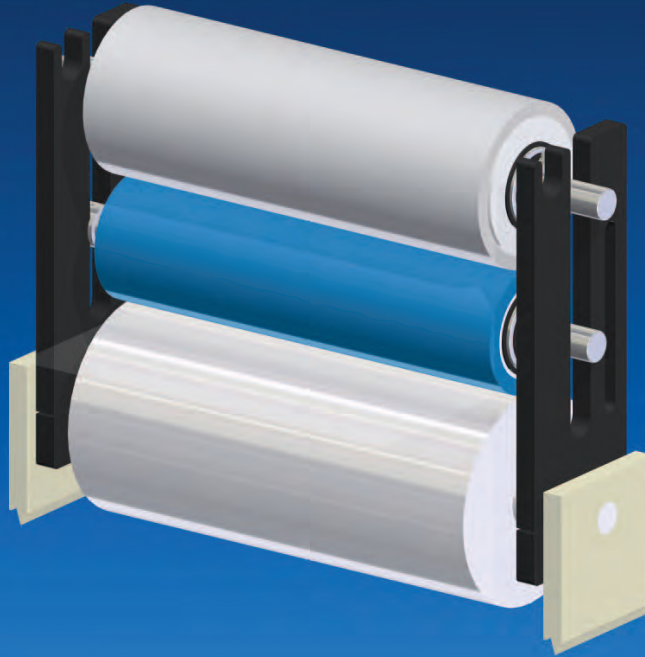

Single-Side, Top-Side Web Cleaner with Simple Mount

ContactClean™ Web by Polymag® Tek, Inc.

2RNWC-3II



Simple and robust, the 2RNWC-3II web cleaner incorporates proven Polymag® Tek technology at a cost effective price. The 2RNWC-3II is a single-side (top-side) web cleaner that mounts to your side frame or dead-shaft idler roll. The Polymag® Tek Blue-S™ Contact Cleaning Roll (CCR) creates a gravity nip along a horizontal web plane with your idler roll, removing contaminants from the web surface. A 3" I.D. adhesive tape roll then continually cleans the CCR. The system takes only minutes to install, but saves hours in potential lost productivity, by increasing quality, reducing downtime and decreasing waste.

Applications

- "Stop & Go" processes
- All substrates

Features

- 1-sided gravity nip - open frame system - up to 96.9% efficiency*
- 3.0" (76 mm) O.D. contact cleaning roll
- Shafted tape mounting style
- Top tape change access
- "Quick release" tape roll end cap
- Simple supported clamps on existing roller or mounts to side-frames
- Plated or coated steel construction
- Can be safely installed in a solvent environment
- Altered designs available

Process Parameters

- Maximum speed 800 fpm (245 mpm)
- Web widths up to 39" (1,000 mm)
- No tape change "on the fly"

Options

- Active static elimination
- Extender™ tape roll oscillator

* Based upon results found in the Polymag® Tek "Dirt Report"

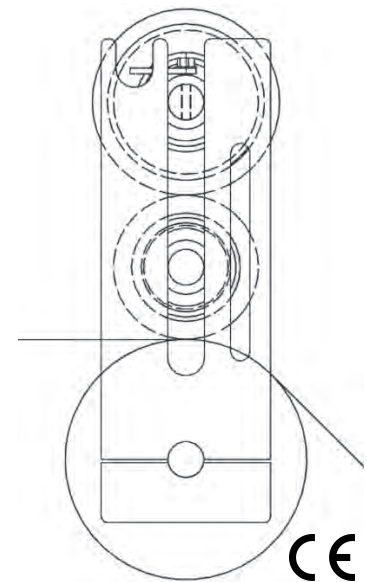

 **PolymagTek**
INCORPORATED

www.polymagtek.com

Phone: 1.800.787.0830 • Fax: 585.235.8395
215 Tremont Street, Rochester, NY 14608