

# Two-Sided, Double Nip Sheet Cleaner

ContactClean™ Sheet by Polymag Tek, Inc

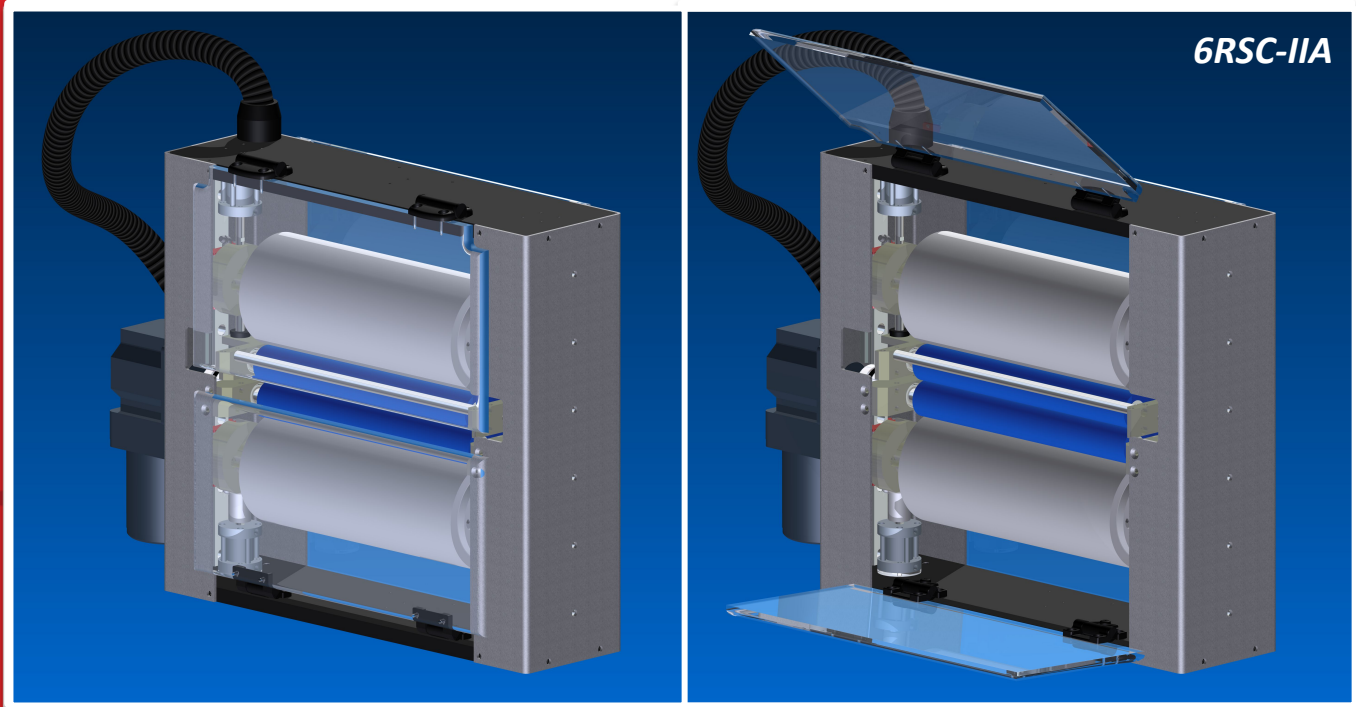

*Polymag® Tek Two-Sided, Sheet Cleaner (6RSC-IIA) offers customized sheet cleaning to meet your most unique needs. Driven Contact Cleaning Rolls (CCRS) remove contamination from the sheet and then transfer contamination to Adhesive Tape Rolls. Custom in-feed and exit conveyers are available to establish the most efficient sheet cleaning processes.*

## Applications

- 2 Sided Sheet Cleaning
- ““Double Nip” - up to 99.9% efficiency

## Features

- 2-sided, gravity, double-nip design
- 1.25” O.D. Contact Cleaning Rolls (CCRS)
- 3.0” I.D. Core, Pre-Cut, Sheeted Adhesive Tape Rolls
- Customizable in-feed and exit conveyors for various substrates
- Pneumatic cylinders to separate rolls when machine stops
- Hinged polycarbonate guard doors for easy tape access
- Active Static Elimination on exit side
- Alternate designs available
- Stainless Steel and Aluminum construction

## Process Parameters

- Sheet widths up to a maximum 30”
- Standard speed up to 30 fpm

## Options

- In-feed active static elimination
- Various conveyor configurations
- Thin film transport system
- Variable speed motor drive
- Jackshaft drive

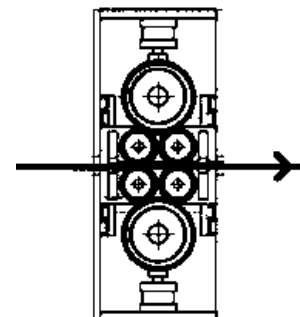

 **PolymagTek**  
INCORPORATED

[www.polymagtek.com](http://www.polymagtek.com)

Phone: 1.800.787.0830 • Fax: 585.235.8395  
215 Tremont Street, Rochester, NY 14608